

No. 659,778.

Patented Oct. 16, 1900.

A. R. WEAVER.

LATHE CHUCK FOR GRINDING WATCH CRYSTALS.

(Application filed Apr. 2, 1900.)

(No Model.)

Fig. 1.

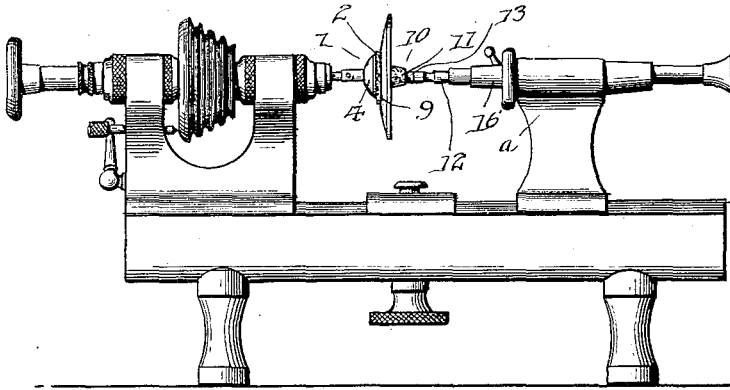

Fig. 2.

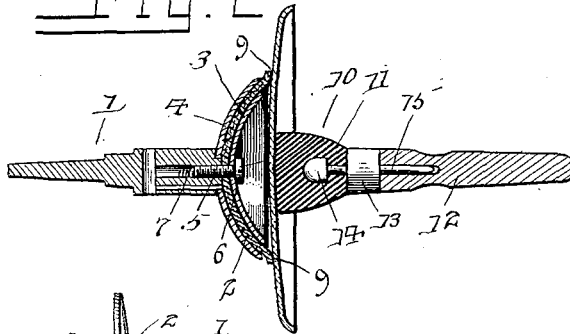
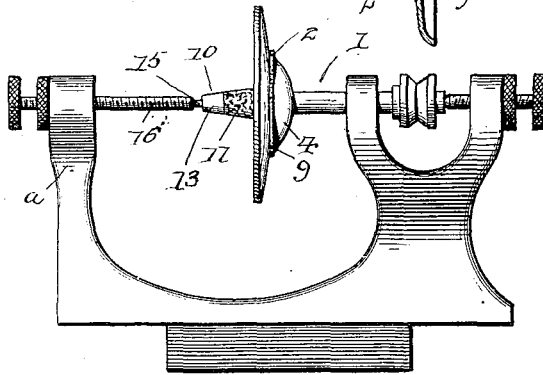

Fig. 3.



Witnesses
J. C. Alden.

J. W. Garner

A. R. Weaver, Inventor

By T. S. Allorneys.

C. A. Snow & Co.

UNITED STATES PATENT OFFICE.

AMASA R. WEAVER, OF HARVARD, NEBRASKA.

LATHE-CHUCK FOR GRINDING WATCH-CRYSTALS.

SPECIFICATION forming part of Letters Patent No. 659,778, dated October 16, 1900.

Application filed April 2, 1900. Serial No. 11,171. (No model.)

To all whom it may concern:

Be it known that I, AMASA R. WEAVER, a citizen of the United States, residing at Harvard, in the county of Clay and State of Nebraska, have invented a new and useful Lathe-Chuck for Grinding Watch-Crystals, of which the following is a specification.

My invention is an improved lathe-chuck for grinding watch-crystals and the like, the object of my invention being to provide a chuck which is adapted to be used for the grinding of watch-crystals and other frangible articles; and it consists in the peculiar construction and arrangements of devices hereinafter fully set forth, and pointed out in the claims.

In the drawings, Figure 1 is a side elevation of a watchmaker's lathe provided with one of my improved chucks for grinding watch-crystals and the like uses. Fig. 2 is a vertical sectional view of my improved chuck on a larger scale. Fig. 3 is an elevation of a lathe differing in form from that shown in Fig. 1 provided with one of my improved chucks.

In the embodiment of my invention I construct a chuck which comprises, essentially, a pair of yielding or elastic friction-heads, between which a watch-crystal or similar article is adapted to be clamped and cushioned, one of the heads bearing on the convex side of the watch-crystal and the other on the concave side thereof. The head 1, which bears against the convex side of the watch-crystal, comprises a circular concavo-convex disk 2, which is made of cork, india-rubber, or other suitable yielding substance adapted to contact frictionally with the watch-crystal and is clamped between a pair of similar-shaped washers 3 4, which are placed, respectively, on the concave and convex sides thereof and are of less diameter than the said disk 2, the washer 3 being of less diameter than the washer 4 and said washers being made of metal, preferably of steel. A screw 5 passes centrally through the washers 3 4 and the friction-disk clamped between them, said screw having an enlarged head, as at 6, which bears centrally on the outer side of the washer 3, and said screw engages a threaded opening 7 in the end of the head 1, which is rotated by the lathe-head in the usual manner. The

screw 5 serves to compress the disk 2 between the washers 3 4 and also to secure said disk and said washers to the head 1, as will be readily understood. The concave face of the disk 2 around the washer 3 projects outwardly beyond said washer to form an annular bearing-surface 9, which contacts with the watch-crystal and engages the same frictionally, the said head being otherwise out of contact with the watch crystal or work. It will be understood that inasmuch as the said head 1 comprises the rubber, cork, or other similar friction-disk and the metallic concavo-convex washers the same is resilient and is adapted to adjust itself to the contour of the contacting face of the watch-crystal or other object.

The head 10, which bears against the concave side of the watch-crystal, comprises a cushion 11, which may be either of cylindrical or tapered form and is preferably made of cork or rubber, but may be made of other elastic material, and a centering arbor 12, the latter comprising an extension 13 on one side of a circular shoulder or head 14 and a centering point 15, which is adapted to revolve in the end of a supporting-stock 16, which may be either secured in the lathe in the usual manner or modified, as shown in Fig. 3, by being provided with screw-threads, whereby it may be adjusted in the standard α , and having a milled head 17, by which it may be turned, and a chuck or clamp-nut 18 to secure it at any desired adjustment. By means of this stock 16 the head 11 is movable toward and from the head 1, so that the crystal may be clamped between said heads and removed when finished, and the said head 11 may be adjusted with relation to the head 1 in order to secure the requisite friction between said heads and the crystal to insure the rotation of the latter, and yet prevent it from being so tightly clamped between the heads as to be broken.

My improved chuck, hereinbefore described, is adapted not only for use in grinding watch-crystals, but for analogous uses, and is especially useful as a chuck for emery-wheels, as will be readily understood.

Having thus described my invention, I claim—

1. In a lathe-chuck of the class described, a friction-head comprising concavo-convex

washers and a similarly-shaped friction-disk of greater diameter clamped between said washers, said friction-disk being elastic, substantially as described.

5 2. In a lathe-chuck of the class described, the combination of a friction-disk, washers on opposite sides thereof and a compression-screw to clamp said washers on said disk, one of said washers being of less diameter than
10 said disk and the latter having an annular bearing-surface projecting beyond the plane of said washer.

3. In a lathe-chuck of the class described,

a friction-head comprising a friction-disk having an annular engaging surface projecting 15 beyond the plane of said disk, and means to secure and rotate said disk, substantially as described.

In testimony that I claim the foregoing as my own I have hereto affixed my signature in 20 the presence of two witnesses.

AMASA R. WEAVER.

Witnesses:

L. G. KEMPSTER,
F. A. BUTLER.